

## Analysis of the Influence of New Combined Process "Equal Channel Angular Pressing-drawing" on the Microstructure and Properties of Deformed Wire

Naizabekov A.<sup>1,a</sup>, Lezhnev S.<sup>2,b</sup>, Volokitin, A.<sup>3,c</sup>, Volokitina I.<sup>3,d</sup>, Panin E.<sup>2,e</sup>

<sup>1</sup>*Rudny industrial institute, Rudny, Kazakhstan*

<sup>2</sup>*Karaganda state industrial University, Temirtau, Kazakhstan*

<sup>3</sup>*Kazakh national technical University after K.I. Satpaev, Almaty, Kazakhstan*

*E-mail: <sup>a</sup>[naizabekov57@mail.ru](mailto:naizabekov57@mail.ru), <sup>b</sup>[sergey legnev@mail.ru](mailto:sergey_legnev@mail.ru), <sup>c</sup>[dyusha.vav@mail.ru](mailto:dyusha.vav@mail.ru),*

*<sup>d</sup>[irinka.vav@mail.ru](mailto:irinka.vav@mail.ru), <sup>e</sup>[cooper802@mail.ru](mailto:cooper802@mail.ru)*

**Abstract:** This article is devoted to analysis of the influence of new combined process "Equal channel angular pressing-drawing" on the microstructure and properties of deformed wire. From the result of investigation, figures of microstructure of deformed wire after third cycle of deformation and graphs of mechanical properties were obtained. It is shown that proposed combined method of deformation of "pressing-drawing" has a significant advantage compared with the existing technology of wire production.

**Keywords:** pressing-drawing, combined process, structure, mechanical properties, wire.

### 1. Introduction

The scope of the wire is wide enough. It is used not only in construction but also in everyday life and production. Through the use of this product, the construction process is faster and better, because it is able to withstand a fairly large load. There are several types of wire. Thus, the wire tie is used for binding the reinforcement in the process of creating concrete slabs. High-strength steel wire used to produce springs of different sizes, ropes and nails, as well as other elements that are required in construction. Copper wire is indispensable when performing electrical work. Without the copper wire, it is impossible to carry out high quality laying wires for electrical power. This wire is able to withstand heavy loads and its service life is not limited. Galvanized wire is used for joining parts and welding the weld. Normal metal wire is used at home and in the workplace. It is used for packaging products and in the manufacture of ruffs for wreaths.

Since the establishment technology of wire, manufacturing remained almost unchanged and the process of production consists of two stages. The first step is obtaining the billet by annealing, and the second stage is the drawing. Thus, the wire gets its natural appearance. At the final stage, the finished wire is wound on a special reel that is called a coil. In that case, if wire is used in certain conditions, it is subjected to additional processing which allows it to withstand the additional load. But now very often, steel wire and wire of non-ferrous metals and alloys make high demands on its strength properties. To increase the strength, you can use doping, but as

you know, this always leads to an increase in the cost of this wire, and in some cases and decrease in the plastic properties of the wire, which is not unimportant. And in such case, for example, with copper wire all impurities lower the electrical conductivity of copper. To achieve improvement of mechanical properties, steel wire and wire of non-ferrous metals and alloys in the remaining value of certain of its properties (for example, for copper – electric conductivity) is possible by obtaining fine-grained structure of these alloys. One of the possible ways of getting shredded patterns is to use large plastic deformations.

The traditional technology of deformation, such as drawing and cold rolling are also accompanied by the refinement of the structure. However, in general, the substructure is cellular with grains elongated in the direction of drawing or rolling, also containing a high proportion of low-angle boundaries. On the other hand, the material obtained by SPD contains a granular structure with relatively small grains and high angles of their disorientation. This fact also has a positive effect on the dynamic recrystallization, and thus on the thermal stability. Moreover, SPD often takes place at low temperatures (environment) which makes it more attractive. But now, none of the SPD methods does not allowed to obtain products which are acceptable in form and dimensions for practical design. After all this concerns the structuring of the metal in long products such as rod and wire.

According to this, the scientists of "Metal Forming" Department of Karaganda state industrial university have developed a new combined process of deformation "Equal channel angular pressing-drawing" (ECAP-D) using the equal channel step matrix and calibrating tool (Fig. 1) to avoid out-of-roundness of the finished wire [1].

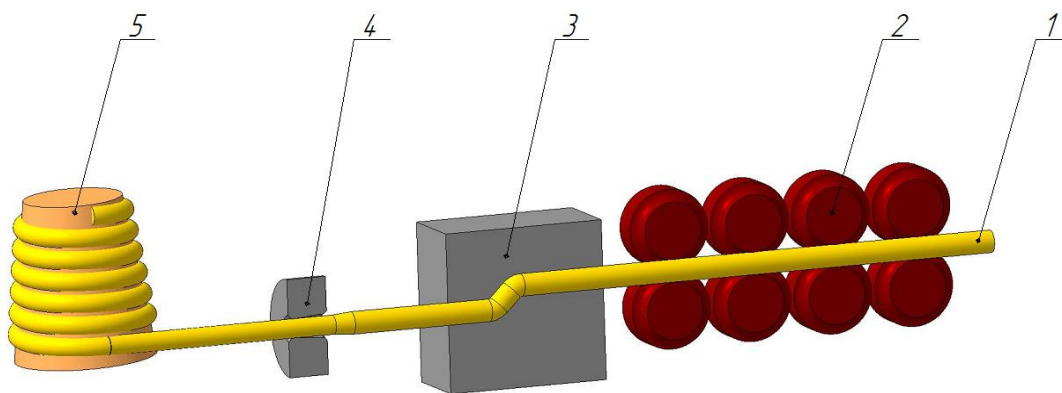

**1 – wire; 2 – pushing device; 3 - equal channel step matrix; 4 – calibrating drawing tool; 5 - winding drum**

**Fig. 1 - Scheme of the combined process of extrusion-drawing**

The essence of the proposed method of deformation is as follows: wire 1 is set in the pushing device 2, which provides pushing of wire into the equal channel step matrix and then in calibrating drawing tool. Essentially the process of pushing of metal does not differ from the standard process of drawing. After that, the end of the workpiece will exit from the portage which is fixed with the aid of exciting mites and wound on the drum of drawing mill.

Studies of the effect of the new scheme of deformation on the quality of steel and aluminum wire have already been done in earlier works [2-5].

The purpose of this work, which was carried out in the framework of the state budget theme "Research and development of a combined process of deformation "pressing - drawing" with the aim of obtaining aluminum and copper wire with high mechanical properties and ultrafine-grained structure" for the program "Grant financing of scientific research for 2012-2014", is investigation of the effect of the new method of deformation on the possibility of obtaining a copper wire of the desired size and shape of the cross-sectional profile with an increased range of mechanical properties.

## 2. Laboratory experiment

To determine the impact of the new continuous method of deformation "pressing-drawing" on the mechanical properties of copper wire, a laboratory experiment in industrial drawing mill B- I/550 M was conducted. For the implementation of the first cycle of deformation before drawing tool with a working diameter of 6.5 mm, an equal-channel step matrix from the channel diameter of 7 mm was installed and the angle of junction of the channel in matrix is  $135^\circ$  (Fig. 2). The matrix was placed in a container for lubricant. The shavings of soap were used as lubricant.

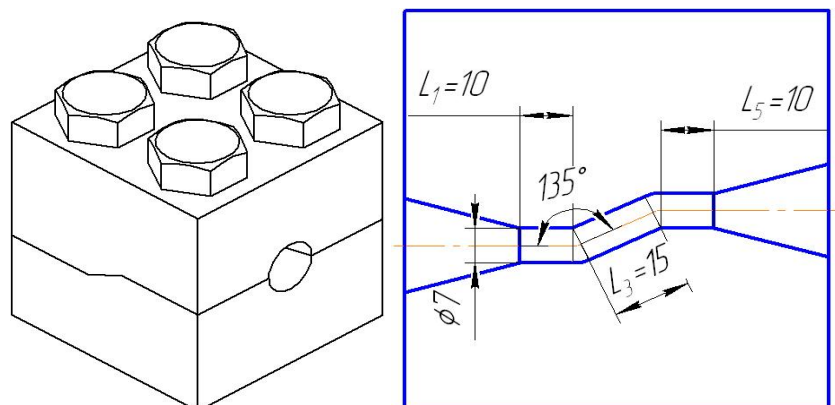

**Fig. 2 - Equal-channel step matrix**

After pressing-drawing, the wire diameter was 6.5 mm. All compression was carried out only in drawing tool, after the output of workpiece from equal-channel step matrix, wire diameter remained unchanged and was 7.0 mm. Experiment was duplicated three times.

After the first cycle of deformation for further research, changed as drawing tool as equal-channel step matrix. So when the implementation of the second cycle of deformation of the working diameter in the drawing tool was 6.0 mm, and the diameter of the channels in matrix was 6.5 mm; in the implementation of the third cycle - 5.5 mm and 6.0 mm respectively.

To identify the advantages of the proposed technology compared with the existing wire production technology, simple drawing of aluminum wire was conducted in the drawing tools with diameters 6.5; 6,0; 5,5 mm. Experiment was duplicated three times. After each stage, the diameter of wire was measured and templates for the manufacture of thin sections were cut in transverse and longitudinal direction.

In the conventional drawing, a shaving soap was also used as a lubricant.

Preparation of thin sections for metallographic studies were carried out according to standard methods, and an optical microscope Leica was employed.

### 3. Results and discussion

The results of the study of the microstructure of the copper wire before and after the third cycle of deformation is presented in figure 3.

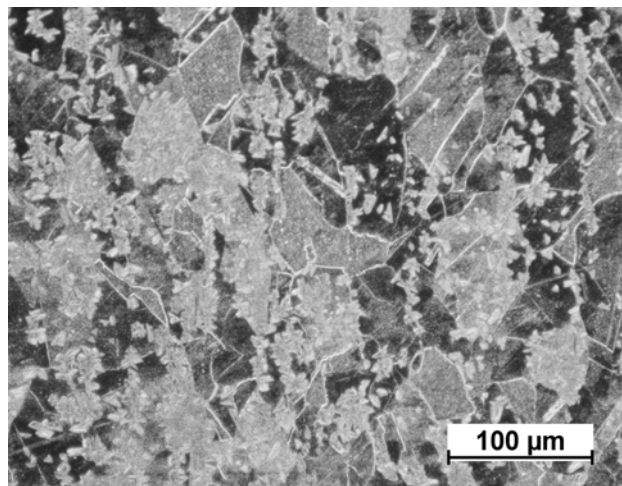

a)

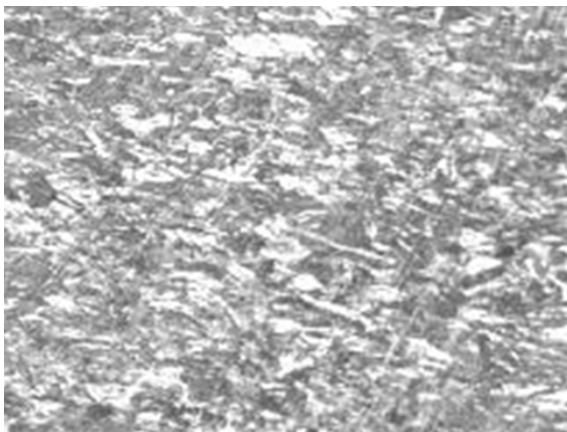

b)

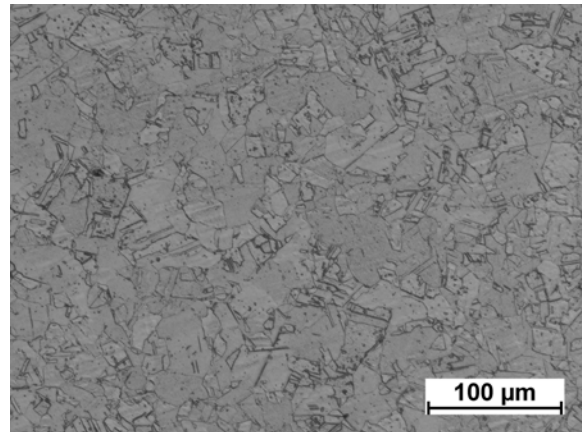

c)

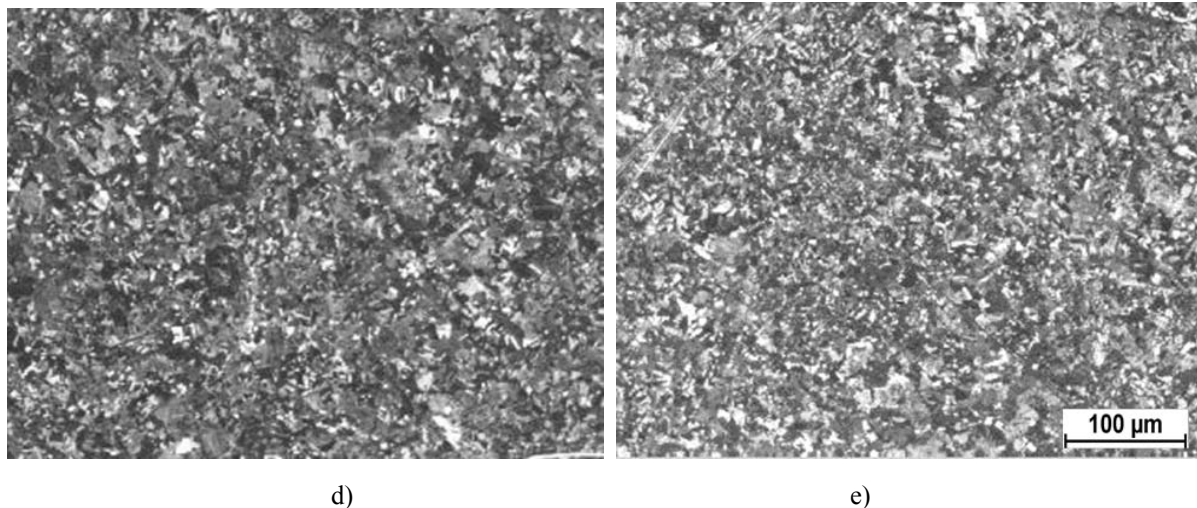

**a - initial structure, 56  $\mu\text{m}$ ;**  
**b – drawing, longitudinal direction; c – drawing, transverse direction 24  $\mu\text{m}$ ;**  
**d - "pressing-drawing", longitudinal direction; e - "pressing-drawing", transverse direction 7  $\mu\text{m}$ .**

**Fig. 3 - Structure of copper wire**

Microstructural studies showed that in the initial state the copper has a coarse structure with a large presence of twins (fig. 3a). After the first cycle of the lug, structure of copper is more ground compared with the original. Cross-sectional microstructure is rather homogeneous and dominated by approximately equal-axial grains. However, structure has some segregation banding in the radial direction, especially in longitudinal section of the workpiece, which leads to an inadequate level of plastic properties of the finished wire, and this in turn may adversely affect the operational parameters of the finished product. Even as a result of significant reductions which is obtained by the wire during drawing, not all of grains were ground and deployed in the direction of the axis of deformation due to uneven distribution of deformation.

As well-known, ultrafine structure during the normal drawing cannot be achieved just by increasing the total degree of deformation, as this technological process is characterized by the scheme of the principal strains, the tensile stresses occurred during the deformation contribute to the metal embrittlement during the drawing, and the maximum value  $\sigma_I \leq \sigma_T$  limits the degree of deformation per pass. [2] Applying an equal channel step die, the full compressive stresses are generated in it at all stages of deformation, thereby reducing the tensile stresses and allows to increase the degree of deformation per pass, and the strength is characteristics with that.

Our proposed combined technology "pressing-drawing" eliminates the disadvantages of the normal drawing process and to obtain a wire with ultrafine structure for a small number of cycles of deformation due to the use of the technological cycle of production of wire equal channel step die. During implementation of this deformation scheme the equal channel step die will be the principal tool for the deformation, i.e. to give the necessary microstructure and mechanical properties of wire. The draw die at the output of the equal channel step die is used more like a supporting role – the role of the sizing tool, i.e. it avoids the out-of-roundness of the finished wire, as well as implementation of a combined scheme of the deformation "pressing - drawing" the effect is achieved by the above given.

The first, the metal deformation in the equal channel step die occurs during the intense deformation scheme – the full non-uniform compression, which is achieved by harmonizing the objectives of the wire channels in the die channels and pushing it through the pushing device 2 (Fig. 1), with the process of pulling the wire through the die channels and draw die implemented by the winding drum 5 (Fig. 1).

The second, when the wire coming through the equal channel step die on its joints of the metal channels, the shear deformation which is promoting the formation of large-angle boundaries are realized so the energy supplied to the sample material does not accumulate predominantly in the form of elastic distortion, and continues to dissipate. As a result, all of this metal in its turn creates the conditions to obtain metal with sub-ultrafine-grained structure for a small number of cycles. As we can see from fig. 3b, the pure copper structure refinement has essentially been occurred for the three passes comparing with the customary drawing and not only on the surface but also in the center of the wire.

The proposed technology after the first cycle of deformation decreases cross-boundary distances in the longitudinal and transverse cross sections. The decrease in cross-border distance due to geometric deformation, i.e. the compression of the original grains. The formation of new boundaries when drawing practically does not occur, all slicing structure occurs in the equal-channel step matrix under shear deformation by twinning. In accordance with Hall-Petch rule drawing on the first passages only leads to increase the strength characteristics of copper by reducing the distance between the boundaries in the longitudinal and transverse cross sections.

It was also found that the second cycle of pressing-drawing leads to the formation of patterns of mixed type. In the study of the obtained patterns, grains of two types were detected: small recrystallized and deformed. This structure is caused by the occurrence of two processes: recrystallization during wire drawing and fragmentation in equal-channel step matrix. The presence in the structure of two types of grains provides high strength and ductility. After the third cycle in the structure there is a significant increase in the share of large angle boundaries (~ 59%) due to a more active course of dynamic return and recrystallization. This is because with decreasing grain, the temperature at which recrystallization of copper decreases. The grain boundaries become more distinct.

Also with increasing number of passes, the trend is towards reducing the number of duplicates associated with a decrease in grain size of copper, which corresponds to an equation of Hall-Petch for the case of deformation twinning, and difficulties manifestations of twinning with decreasing grain size should be expected.

In addition to studying changes in grain size during deformation under the current and proposed technology, we have investigated the mechanical properties of the copper wire after each cycle of deformation under the current and proposed technology of deformation; graphs are presented in fig. 4.

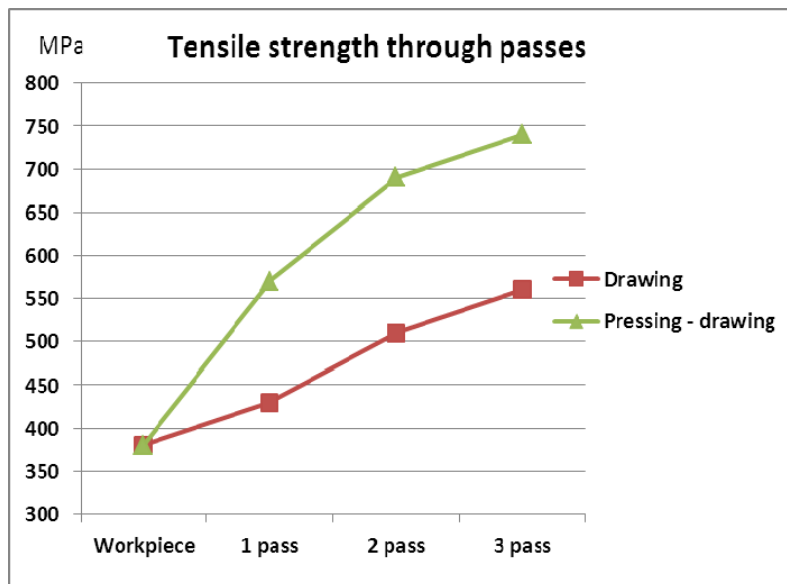
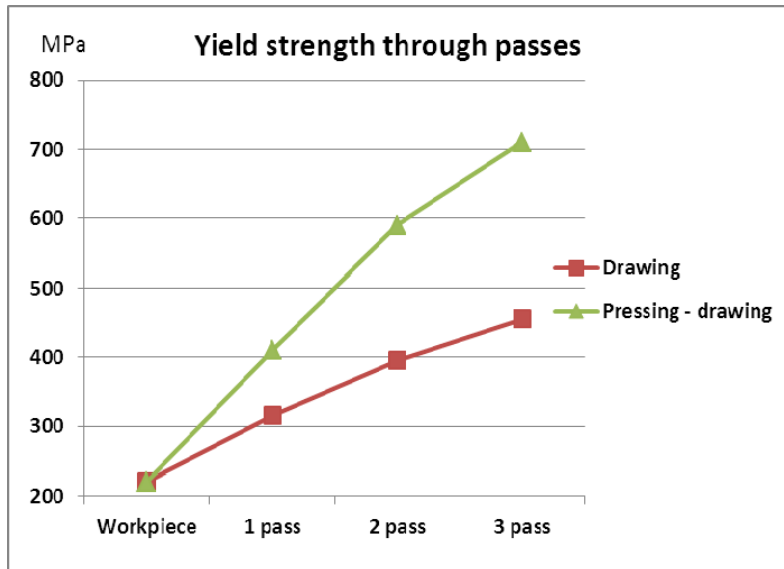

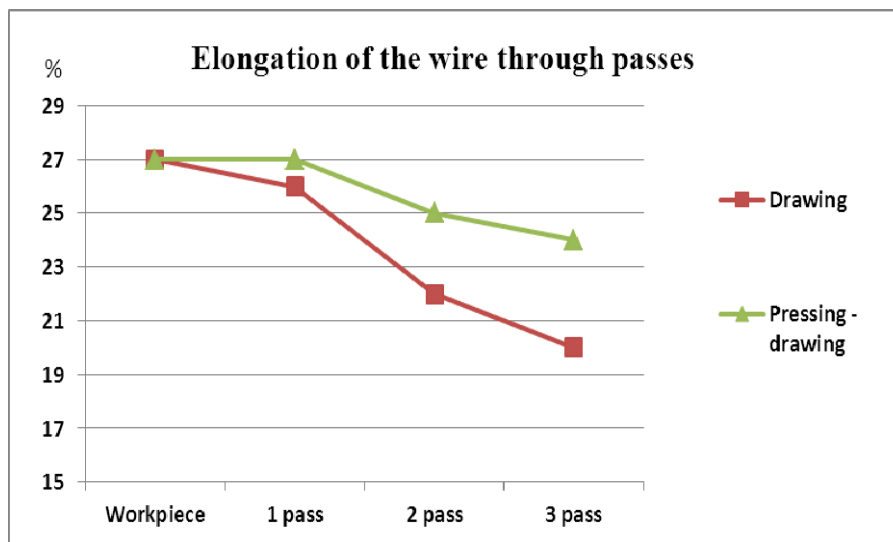
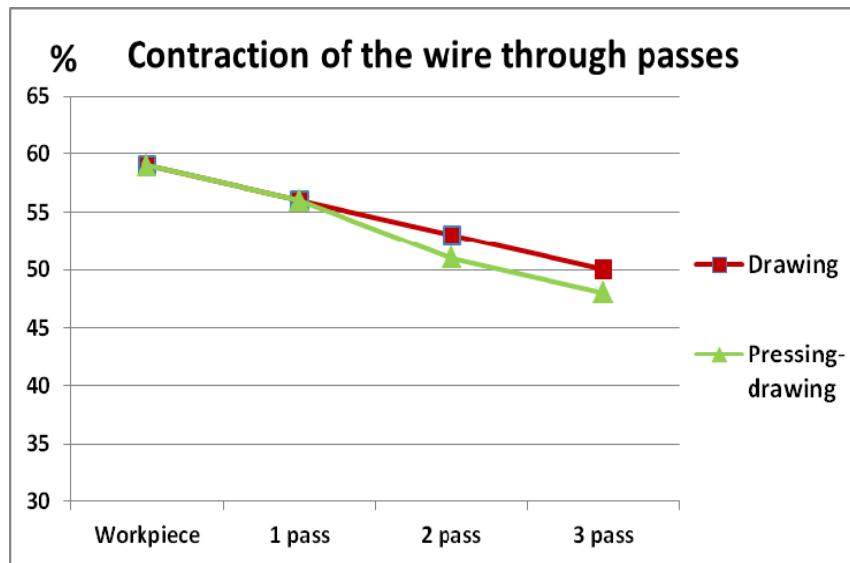

**Fig. 4 - Graphs of depending mechanical properties of the copper samples from number of passes**

Analysis of the graphs showed that both methods increase the strength characteristics with increasing number of passes, plastic characteristics are reducing, but in the proposed method elongation after the third passage is 36% above than at traditional drawing. Measurement of the tensile strength showed that the combination of the method of pressing-drawing provides a significant increase in the level of strength as compared with the original condition and 20% higher than the strength of traditional drawing after the third passage. From the graph shown in fig. 4 it is seen that the tensile strength of copper wire deformed to the combined process of "pressing-drawing" after the third passage is increased to 180 MPa compared with the wire after classical drawing. And the yield strength of the wire, after the third pass using the combined process increased by 255 MPa, compared with the wire after classical drawing. As known from the ratio of the Hall-Petch, the grain size of polycrystalline metals has a great influence on the value of the yield strength and mechanical properties of the material. A



crucial role in high-strength ultrafine-grained alloy plays an additional hardening due to the high density of dislocations along grain boundaries.

Based on this, we conclude that the values of the mechanical characteristics of the wire, deformation of new technology of pressing-drawing" is higher than the wire obtained by a traditional drawing with the highest strength characteristics of conventional lug achievable by new technologies pressing-drawing in fewer passes, which creates the preconditions for reducing the intensity of use of the working tool, therefore, its depreciation, cost of energy and material resources are less.

#### **4. Conclusions**

On the basis of the conducted research, it can be concluded that the proposed combined method of deformation of "pressing-drawing" has a significant advantage compared with the existing technology of production of copper wire. This method of deformation is combining two methods: intensive plastic deformation in equal-channel step matrix and the process of drawing through calibrating drawing tool, allows to obtain a copper wire with ultrafine-grained structure, the required dimensions and cross-sectional shape with an insignificant number of cycles of deformation. It just want to note that this method of deformation when implementing in production does not require significant economic investment and significant retrofit existing drawing mills. It was shown that the implementation of this combined process only requires the addition in the design of the equipment which specially manufactured equal-channel step matrix.

#### **5. References**

- [1] A.V. Volokitin. Investigation of the influence of the combined process of deformation "pressing-drawing" on the mechanical properties of steel wire.// Abstracts of scientific conference "Innovation in engineering, technology and education", Karaganda, 2012. Part 4. – p. 95-96.
- [2] S.N. Lezhnev, A.V. Volokitin, I.E. Volokitina. Study of the impact of the new combined process of deformation "pressing-drawing" on microstructure and mechanical properties of aluminum wire. Metal forming, Kramatorsk, DSMA, 2013 №2. – p. 203 – 207.
- [3] S.N. Lezhnev, A.B. Naizabekov, A.V. Volokitin, I.E. Volokitina New combined process "pressing-drawing" and its impact on the properties of deformable aluminum wire. Procedia Engineering Vol. 81 (2014) - pp 1505 – 1510.
- [4] A.B. Naizabekov, S.N. Lezhnev, A.V. Volokitin. Study of the impact of the new combined process of deformation "pressing-drawing" on evolution of microstructure of steel wire. XIII International scientific conference *New technologies and achievements in metallurgy and material engineering*, Czestochowa, Poland, 2012. - p. 433-437.

- [5] S.N. Lezhnev, A.B. Naizabekov, A.V. Volokitin Research of a new method of deformation -"pressing – drawing" on mechanical properties of steel wire. 22-th International Conference on metallurgy and materials METAL, Brno, Czech Republic, 2013.
- [6] Krasilnikov L.A., Lysenko A.G. Wiredrawer of wire. Publishing office: Metallurgy. 1987. 320 pages.